

# HOKUYO

PL d Category3 | SIL 2 Type3

## Safety Laser Scanner UAM-05LP-T301

The Smallest Size in the World  
with a Versatile Range for  
Safety Applications

Actual  
Size



# “Small and light!”



## Compact and User Friendly

The compact design for installation on AGVs, AGCs as well as in vertical guarding applications.

**Size** | Height 95.0×Width 80.0×Length 80.0 mm

**Weight** | 0.5 kg

**Conformity Standards**

IEC61496-1/3	Type3
IEC61508	SIL 2
ISO13849-1	PL d Category3
UL508	
UL1998	
UL61496-1	Type3
CSA C22.2	No. 14



### Collision Prevention



32 safety area patterns to accommodate the AGV travel path for collision prevention.

### Presence Detection

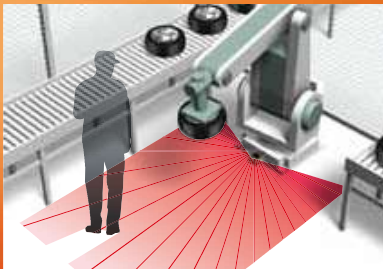

Detects humans or objects entering the hazardous area.

### Intrusion Detection



Detects access into critical zone. Reference boundary monitoring feature improves the safety by detecting the gaps around the protection zone and sensor's misalignment.

# Expands The Range of Safety Applications

## Protection over a Wide Range

Up to 5 meters of protection zone and 20 meters of warning zone configuration to suit various application requirement.

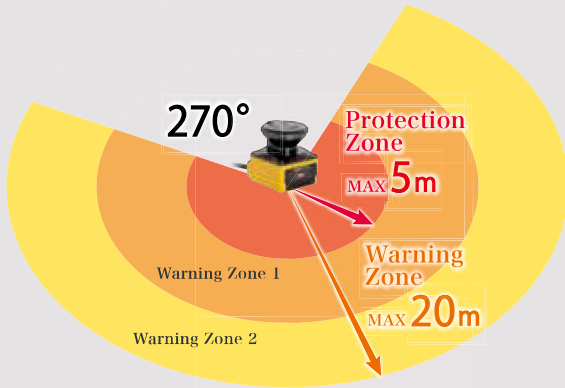

## Data Output via Ethernet

Measurement data can be acquired via Ethernet with status of input/output signals and cyclic redundancy check code. Also supports command in SCP2.0 protocol.

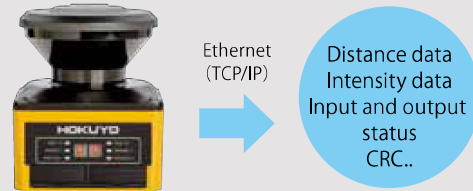

## SD card for Configuration

Configuration data can be saved in a SD card which in turn can be used for configuring the UAM without connecting it to a PC. The feature is useful while replacing the UAM or configuring multiple units with the same settings.



## Master-Slave Function

Maximum 4 units of UAM can be interconnected for Master-Slave operation when multiple units are required to guard the hazardous area. The system can be controlled by connecting the input and output signals to Master unit only.

Important Note: It is not possible to control the actuators via master-slave bus communication.

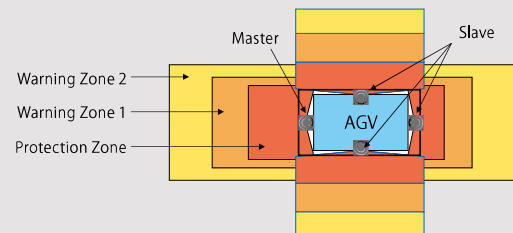

## Encoder Input

In AGV applications, area is switched depending on the vehicle's speed. Speed and direction of travel provided via encoders are constantly monitored to switch the area and stop the AVG during abnormal travel.

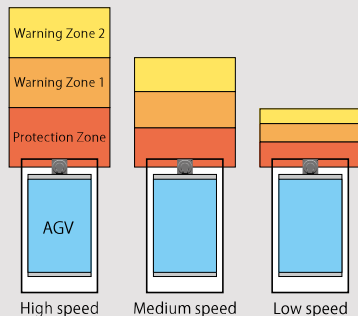

## Dual Protection Mode

UAM can simultaneously protect two hazardous areas. Separate OSSD signals are triggered for the respective protection zones making it possible to guard two machines with a single UAM.

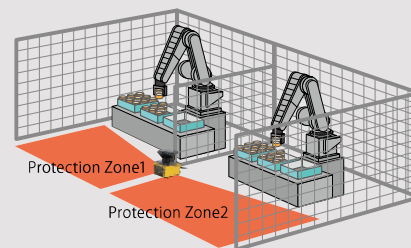

# Easy Configuration of Complicated Zones

## User Friendly Interface

Simple user interface to configure even a complicated zone by simultaneously viewing the measurement data. Zones can be configured with 3 different methods.

Before settings

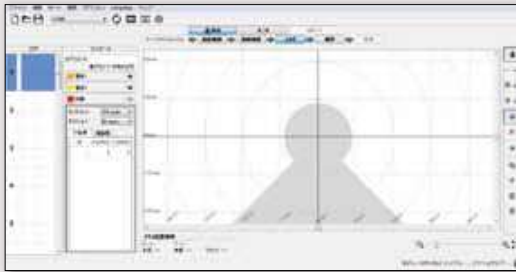

After settings

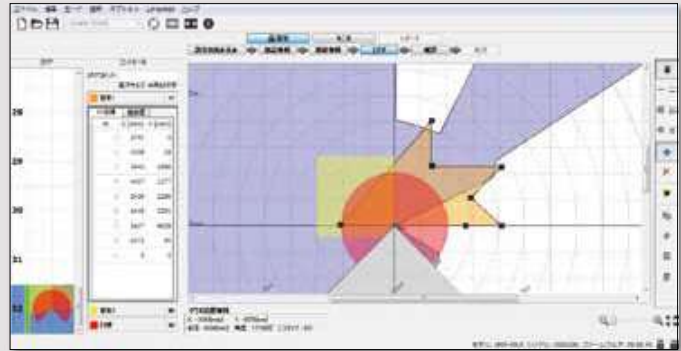

## Category

### Main unit

Appearance	Model number	Product code	Notes
	UAM-05LP-T301	UUAM005	CD-ROM consists of the configurator software and manual
	UAM-05LP-T301C	UUAM006	

### Extension cable without connector (Option)

Appearance	Specification	Model number	Product code	Notes
	Cable length: 10m	UAM-5C10	UZ00066	Bare cable (T301 only)
	Cable length: 20m	UAM-5C20	UZ00067	

### Extension cable with connector (Option)

Appearance	Specification	Model number	Product code	Notes
	Cable length: 2m	UAM-5C02C	UZ00081	Each UAM requires 1 cable (T301C only)
	Cable length: 5m	UAM-5C05C	UZ00082	
	Cable length: 10m	UAM-5C10C	UZ00083	
	Cable length: 20m	UAM-5C20C	UZ00084	





### USB cable (Option)

Appearance	Specification	Model number	Product code	Notes
	Micro USB Length: 1m	UAM-MUSB	UZ00065	For UAM configuration

### Ethernet cable (Option)

Appearance	Specification	Model number	Product code	Notes
	Length: 3m	UAM-ENET	UZ00062	Ethernet cable is necessary for distance data output

### Brackets and optical window (Option)

Appearance	Specification	Model number	Product code	Notes
	Base mounting bracket	UAM-BK03	UZ00059	
	Rear mounting bracket	UAM-BK04	UZ00060	
	Cover bracket	UAM-BK05	UZ00061	To protect the optical window
	Optical window	UAM-W002	UZ00064	For replacement when damaged and only to be fitted by approved personnel.

### UAM Project Designer (Option)

Appearance	Specification	Model number	Product code	Notes
	CD-ROM	UAM-CD03	UZ00063	UAM Project Designer for functions and zone configuration

## Specification

Subject		Specifications	
Model		UAM-05LP-T301	UAM-05LP-T301C
Detection property	Protection Range	Max : 5m	
	Warning Range	Max : 20m (Non-safety) *1	
	Distance Tolerance *2	+100mm	
	Detection Capability	From Black-Reflector Sheet (1.8%) to Retro-Reflector Sheet	
	Detection Range	270°	
	Minimum Detectable Width	φ30mm(Max : 1.8m) φ50mm(Max : 3.0m) φ70mm(Max : 5.0m)	
	Scan Frequency	30ms (Rotational Speed 2000rpm)	
	Area Pattern	Max 32 patterns for safety and 64 patterns for non-safety	
Optics	Element	Pulsed Laser Diode	
	Wave Length	905nm	
	Safety Class	Laser Class 1	
Type	Type 3 (IEC 61496-1, IEC 61496-3)		
Functional Safety	SIL 2 (Type B, HFT=1) (IEC61508)		
PFHd	7.8×10 <sup>-9</sup> (T1=20 year) : When master slave function is not in use. 1.6×10 <sup>-7</sup> (T1=20 year) : When master slave function is in use.		
Housing	Size	80.0mm (W), 80.0mm (D), 95.0mm (H) (without cable)	
	Weight	0.5kg	
	Protection	IP65	
	Case Material	Body : Aluminum / Optical Window : Polycarbonate	
Connection Cable	Flying lead cable length : 3m	Cable with water proof connector / cable length : 0.3m	
Power Supply	DC 24V ±10% : when operation using converter power supply DC 24V -30%/+20% : when operation using battery		
Supply Current	Normal (without load)	6W	
	Max. (with load)	50W	
Output	OSSD1/2 (Safety)	Output type (High side SW) Output current (Max : 500mA) *3 Leak current (Max : 1mA) AWG 26 Load tolerance (L/R=25ms, C=1μF)	
	OSSD3/4 (Safety) WARNING 1/2 (Non-Safety)	Output type (High side SW) Output current : (Max : 250mA) *3 Leak current (Max : 1mA) AWG 28 Load tolerance (L/R=25ms, C=1μF)	
	RES_REQ 1 RES_REQ 2 MUT_OUT 1 MUT_OUT 2	Output type (PNP Transistor) Output current : (Max : 200mA) *3 Leak current (Max : 1mA) AWG 28	
Input	Area pattern 32 (5 Inputs x 2 Channels) EDM1/EDM2 MUTING1/MUTING2 MUTING3/MUTING4 OVERRIDE1/OVERRIDE2 RESET1/RESET2 ENC_A1/ENC_A2 ENC_B1/ENC_B2	Input Impedance 4.7 kΩ AWG 28	
Interface	Configuration	USB2.0 (USB micro type-B connector)	
	Data output	Ethernet 100BASE-TX (Water proof connector)	
Environmental Resistance	Temperature	-10°C to +50°C (No freezing)	
	Storage Temperature	-25°C to +70°C (No freezing)	
	Humidity	95% RH with no condensation	
	Storage Humidity	95% RH with no condensation	
	Surrounding Intensity *4	Less than 1500lx	
Vibration	Frequency range : 10~55Hz Sweep rate : 1 octave/min Amplitude : 0.35mm ±0.05mm		
Bump	Acceleration : 98m/s <sup>2</sup> (10G) Pulse duration : 16ms		
Outdoor Operation	Not permitted		
Altitude	Below 2000m		

\*1. Distance when reflectance of the object is 90% or above.

\*2. Additional distance of 200 mm is needed when the UAM is working under high reflective background.

\*3. Total current supply of OSSD output and Warning output should be below 1.0A.

\*4. When the light sources are located at ≥5° from the detection plane of UAM.

## Wiring example

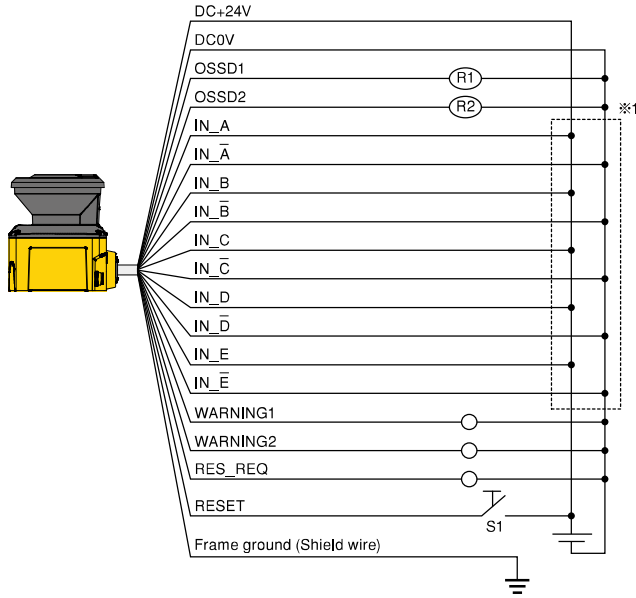

R1 and R2 : External equipment (Safety relay, Electromagnetic contactor)

S1: Interlock reset switch

\*1: Refer to user's manual for details on area switching.

Color	Signal	Function	Description	AWG
Brown	+24V DC	Power	Power Supply : DC 24V	22
Blue	0V DC	Power	Power Supply : DC 0V	22
Red	OSSD1	Output	Protection zone output 1	26
Yellow	OSSD2	Output	Protection zone output 2	26
Red/Black	OSSD3/ WARNING1	Output	Protection zone output 3/ Warning zone output 1	28
Yellow/Black	OSSD4/ WARNING2	Output	Protection zone output 4/ Warning zone output 2	28
Purple	IN_A	Input	Area Switching Input A	28
Gray	IN_B/ MUTING3	Input	Area Switching Input B/ Muting input 3	28
White	IN_C/OVERRIDE1/ ENC1_A	Input	Area Switching Input C/Override input 1/Encoder input 1_A	28
Pink	IN_D/MUTING1/ ENC1_B	Input	Area Switching Input D/Muting input 1/Encoder input 1_B	28
Green	IN_E/EDM1	Input	Area Switching Input E/ External device monitoring 1	28
Purple/Black	IN_A-bar	Input	Area Switching Input A invert	28
Gray/Black	IN_B-bar/ MUTING4	Input	Area Switching Input B invert/ Muting input 4	28
White/Black	IN_C/OVERRIDE2/ ENC2_A	Input	Area Switching Input C invert/ Override input 2/Encoder input 2_A	28
Pink/Black	IN_D/MUTING2/ ENC2_B	Input	Area Switching Input D invert/ Muting input 2/Encoder input 2_B	28
Green/Black	IN_E/EDM2	Input	Area Switching Input E invert External device monitoring 2	28
Yellow/Green	RESET1	Input	Reset input 1	28
Yellow/Blue	RESET2	Input	Reset input 2	28
Orange	RES_REQ1/ MUT_OUT1	Output	RES_REQ 1 : Request output 1 MUT_OUT 1 : Muting state output 1	28
Orange/Black	RES_REQ2/ MUT_OUT2	Output	RES_REQ 2 : Request output 2 MUT_OUT 2 : Muting state output 2	28
White/Blue(TP)	RS485+	Communication	Communication Protocol RS485	28
White/Red(TP)	RS485-	Communication	Communication Protocol RS485	28
Shield wire	FG	-	Frame ground	-

## Input/Output circuit

### OSSD output circuit

OSSD/Warning output is output type.

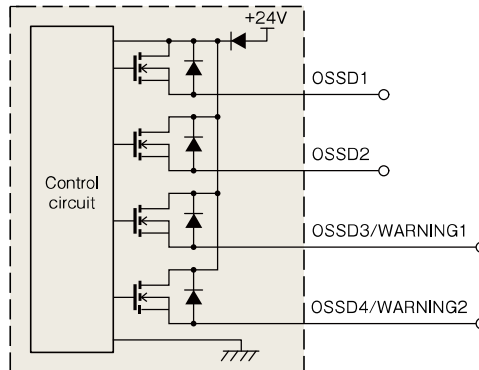

### Other Output circuit

RES\_REQ1, RES\_REQ2, MUT\_OUT1,  
MUT\_OUT2 output circuit.

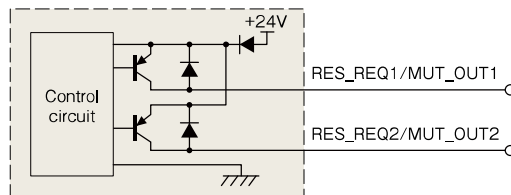

### Input circuit

Area input, EDM1, EDM2, RESET1,  
RESET2, MUTING1, MUTING2,  
MUTING3, MUTING4, OVERRIDE1,  
and OVERRIDE2

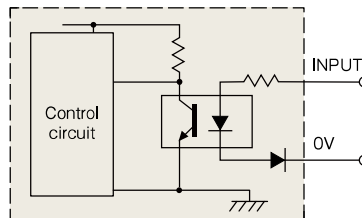

## External Diagram

### Sensor

#### UAM-05LP-T301

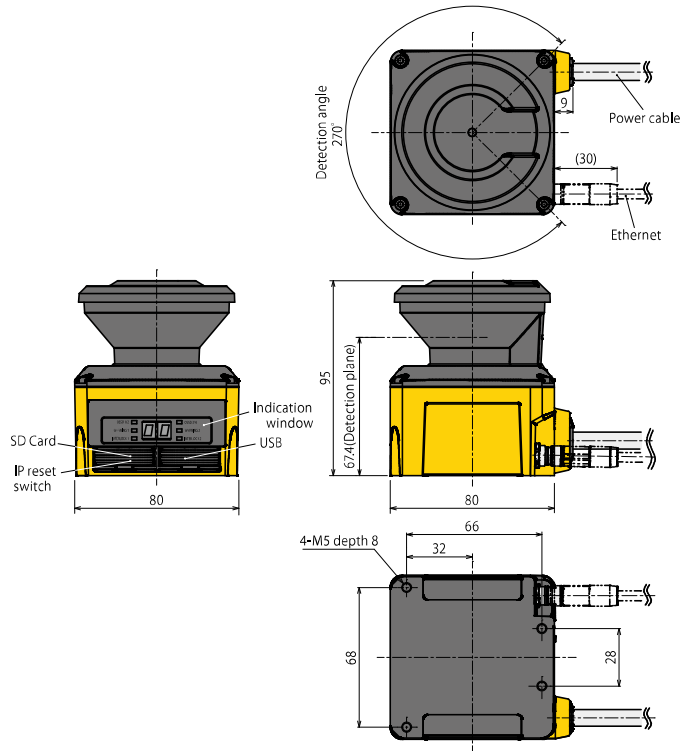

#### UAM-05LP-T301C

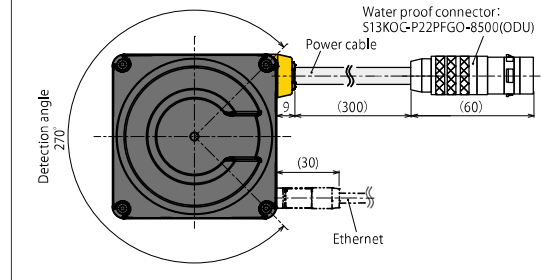

### Fixing of Rear mounting bracket with Cover bracket

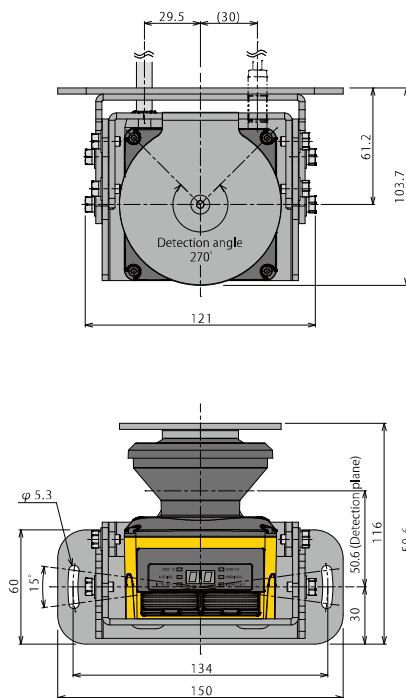

### Fixing of Base mounting bracket with Cover bracket

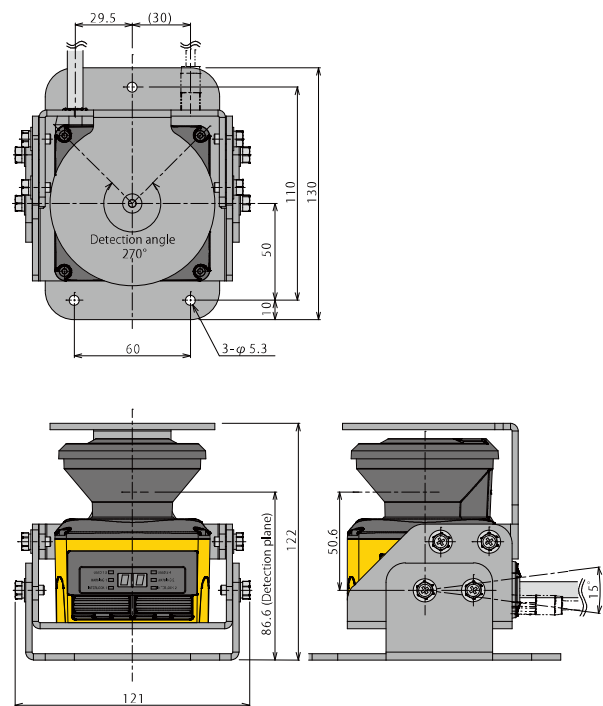

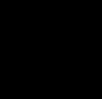
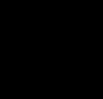

ISO14001 Certified  
JQA-EM3873



ISO9001 Certified  
JQA-1742



### Caution for safety use

- Read instruction manual carefully before use.
- Products published in this brochure are intended to be used under specific conditions.
- For product related questions or technical issues, please contact our offices.



## HOKUYO AUTOMATIC CO.,LTD.

Osaka HU Building, 2-2-5 Tokiwamachi, Chuo-Ku,  
Osaka, Japan, 540-0028  
TEL: +81-6-6947-6333 FAX: +81-6-6947-6350  
URL <http://www.hokuyo-aut.jp>  
E-mail: [info@hokuyo-aut.jp](mailto:info@hokuyo-aut.jp)

- The contents of this catalog are based on material from September 2016. External dimensions and specifications may change without notice.